

# Sturdi-Wall Design and Use Guide

*(drill set & wet set models)*

May 28, 2015



**PERMA**  
**COLUMN**

400 Carol Ann Lane  
Ossian, IN 46777  
PH: 800-622-7190  
[www.permacolumn.com](http://www.permacolumn.com)

*Project Number S021-12*

By:



Brent Leatherman, P.E.  
Dimitry Reznik, P.E.  
Timber Tech Engineering, Inc.  
[www.timbertecheng.com](http://www.timbertecheng.com)  
email: [bl@timbertecheng.com](mailto:bl@timbertecheng.com)

**East:** 22 Denver Road, Suite B Denver, PA 17517  
717.335.2750 Fax: 717.335.2753

**West:** 206 S. Main St, P.O. Box 509 Kouts, IN 46347  
219.766.2499 Fax: 219.766.2394

# Table of Contents

## Part 1: Standard Sturdi-Wall (Drill Set) Model

- 1. Sturdi-Wall Design Overview.....Page 3
- 2. Sturdi-Wall Descriptions .....Page 3
- 3. Steel Bracket Design.....Page 4
- 4. Concrete Anchors.....Page 4
- 5. Wood Connection .....Page 5
- 6. Recommended Sturdi-Wall Installation Details .....Page 5
- 7. Sturdi-Wall Bracket Design Chart.....Page 8

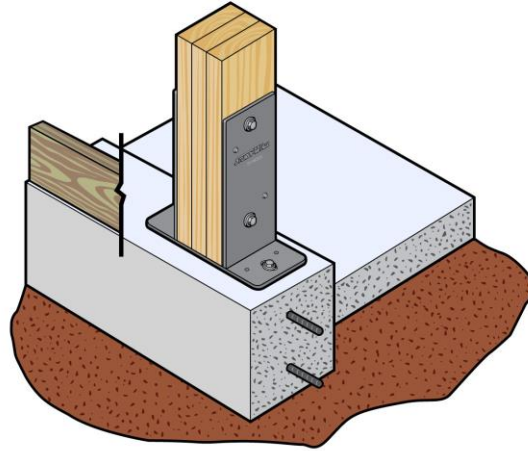

## Part 2: Sturdi-Wall Plus (Wet Set) Model

- 8. Sturdi-Wall Plus (Wet Set) Design Overview .....Page 10
- 9. Sturdi-Wall Plus Descriptions.....Page 10
- 10. Steel Bracket Design.....Page 11
- 11. Concrete Reinforcing Bar Design.....Page 11
- 12. Wood Connection .....Page 12
- 13. Recommended Sturdi-Wall Plus Installation Details Page 12
- 14. Sturdi-Wall Plus Bracket Design Chart .....Page 15
- 15. Summary and Conclusion .....Page 17

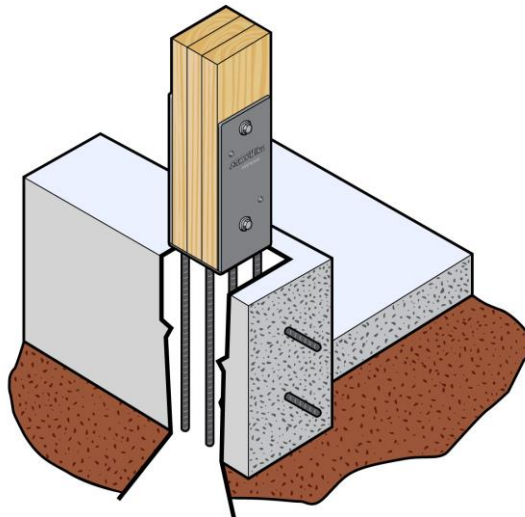

# Part 1: Standard Sturdi-Wall (Drill Set) Model

## 1. Sturdi-Wall Design Overview

Standard Sturdi-Wall anchor brackets are designed to connect wood columns to a concrete foundation in a typical post-frame building application using a drill set installation method. This section contains drawings and descriptions for each of the Sturdi-Wall models, a chart showing allowable shear and uplift, descriptions of several methods for attachment to concrete, and discussion of design assumptions. See Part 2 of this manual for information on a wet set installation.

## 2. Sturdi-Wall Descriptions

Dimensions for the SW60, SW46, SW66, SW63, SW64, SW80, SW83, SW84, and SW85 are given in Figure 2.1. The brackets are constructed with 1/4" structural steel plate with a minimum yield strength of 40 ksi, and 1/4" fillet welds of E70XX electrodes. Each assembly has a proprietary powder coat finish. The SW46 is to be used with a 4x6 wood post, SW66 with a 6x6 wood post, SW63 with a 3-ply 2x6 mechanically laminated column, SW64 with a 4-ply 2x6 laminated column, SW83 with a 3-ply 2x8 laminated column, SW84 with a 4-ply 2x8 laminated column, and SW85 with a 5-ply 2x8 laminated column or 8x8 wood post. The inside dimension of the brackets allow for an 1/8" total tolerance between the steel bracket and wood column. Glued laminated columns are acceptable; however, appropriately sized wood shims need to be added on both sides of the pocket to provide a snug fit as shown in Figure 2.2 (1/8" total tolerance is acceptable). **The shim should be APA B-C Exterior plywood (or equivalent), no more than 1/4" thick, and have the same dimensions as the vertical leg of the bracket. The shim should be fastened to the column with 2 beads of Builders Choice 490 construction adhesive by Liquid Nails (or equal) and (6) 0.113"x2.375" nails.** The single brackets (SW60, SW80) shall be used as pairs and fastened using the same connectors as the fully assembled brackets.

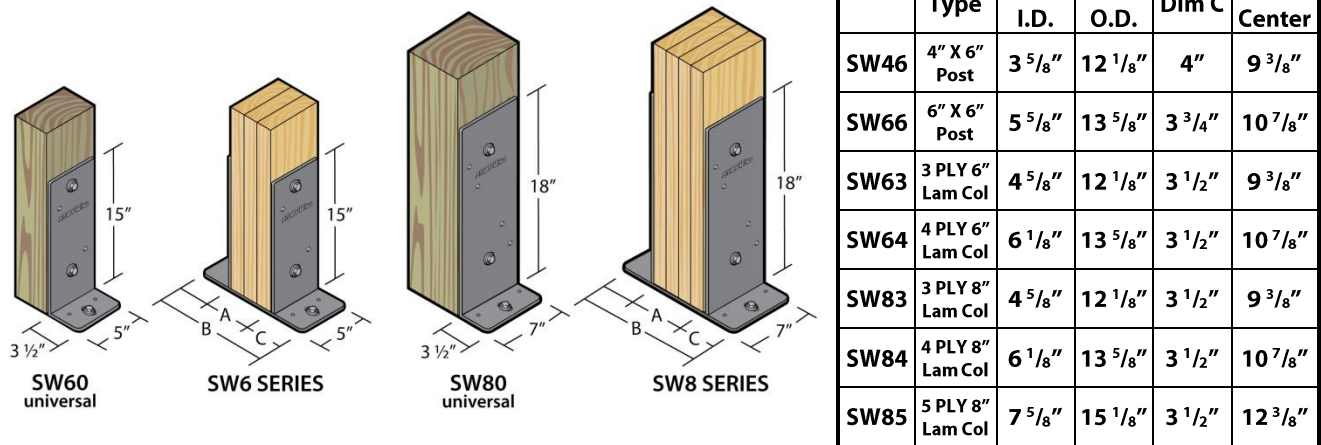
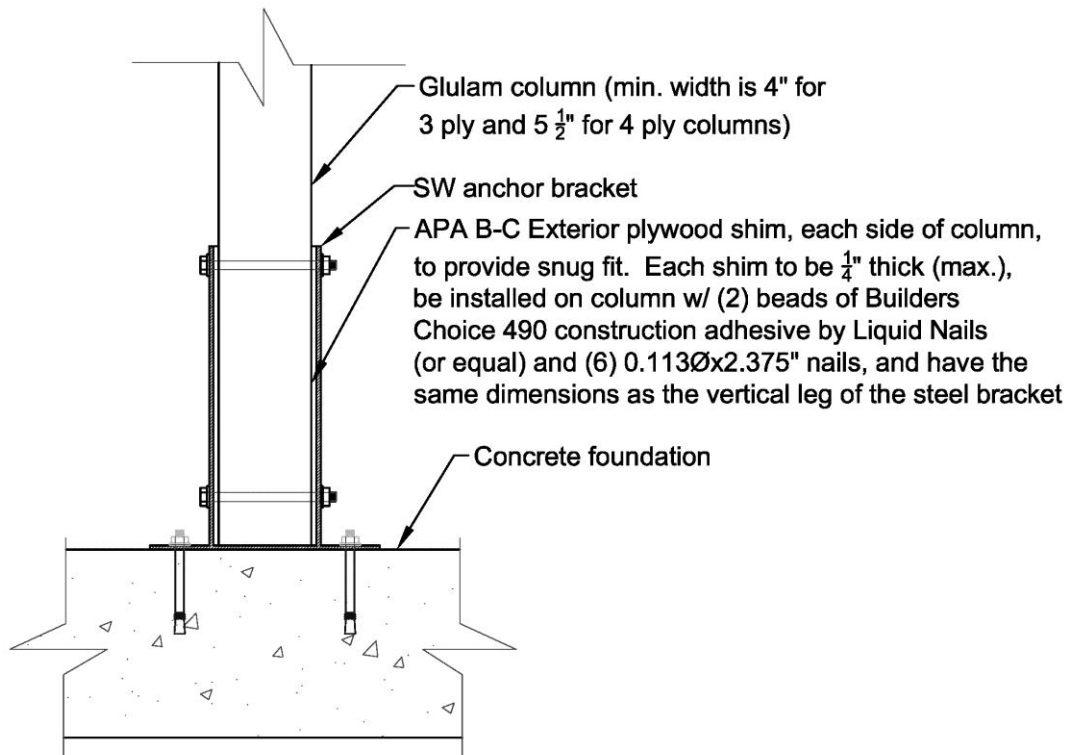

Figure 2.1: Sturdi-Wall Descriptions



**Figure 2.2: Sturdi-Wall Shim Detail**

### 3. Steel Bracket Design

The forces applied from the building columns to Sturdi-Wall brackets are a vertical uplift force, a downward gravity force, and a horizontal shear force. The wood columns need direct bearing on the bottom to transfer axial loads directly into the concrete foundation. The Sturdi-Wall brackets are assumed to have no moment capacity. The building must be designed to resist lateral loads through diaphragm action or other bracing means. All mechanical fasteners are to be installed as per the manufacturer's recommendations and this design manual. The brackets consist of 1/4" steel with 5/8" diameter holes for the bolts in the vertical leg, and 3/4" x 1 1/2" slotted holes for concrete anchors in the base. The brackets also have holes for screws near the bolts in the vertical legs.

### 4. Concrete Anchors

This manual includes recommendations for anchor "L" bolts, epoxy anchors, expansion anchors, and screw anchors for the steel to concrete connection.

#### 4.1 Anchor "L" Bolts

The anchor "L" bolts are to be typical ASTM A307 grade C right angle bend cast in place anchor bolts. These are set in wet concrete and must be placed within the tolerance of the slotted hole in the bottom of the bracket.

#### 4.2 Epoxy Anchors

Epoxy or adhesive anchors provide the maximum amount of uplift resistance; however, they must be installed in a properly sized hole and within a set temperature range in order to be effective.

#### 4.3 Expansion Anchors

Expansion anchors transfer forces to the concrete by means of an expansion sleeve or wedge which presses out against the sides of the hole as the top nut is tightened. Since the expansion forces are transferred to the concrete base material, these anchors have a greater minimum distance to the concrete edge than the other anchors.

#### 4.4 Screw Anchors

Screw anchors have a hex head and a threaded shaft which can be installed with an impact wrench or conventional hand socket. There are no expansion forces transferred to the concrete base material so they can be installed closer to the edge than traditional expansion anchors.

### 5. Wood Connection

The wood to steel connection is made with (2) ½” diameter A307 (grade 2) bolts in double shear and ¼” x 3” strong drive screws (SDS) by Simpson Strong Tie (or equal) in single shear installed from each side. Typically, one screw is installed from each side of the bracket at each bolt except the SW8 series has 2 screws on each side at each bolt. Screws help prevent stress concentration around the bolt which would cause splitting of the wood members. The wood to steel connection was analyzed as per the National Design Specification for Wood Construction by the American Forest and Paper Association using Southern Yellow Pine wood columns. No wet service reductions have been made since the wood portion is not in contact with the soil or concrete and it is assumed to be used in an enclosed building. If the brackets are to be used in an environment where the moisture content of the wood in service will exceed 19% for an extended period of time, pressure treated wood and galvanized or stainless steel bolts should be used, and a wet service factor of 0.7 applied to the allowable shear and uplift values in Table 6.1. The design of the wood post above and the concrete foundation below the Sturdi-Wall bracket are the responsibility of others. Lateral bracing of the building is also the responsibility of others.

A barrier membrane between the pressure treated wood and the steel bracket is not necessary. The steel bracket is protected by the Perma-Column EpoxyZirc Coating pretreatment process. The ASTM B-117 Salt Spray Testing results show that the Perma-Column EpoxyZirc Coating outperforms the G185 galvanized coating, which is thicker than the galvanized coating prescribed by the ASTM A653.

### 6. Recommended Sturdi-Wall Installation Details

Figures 6.1 and 6.2 illustrate the recommended installation of an SW 4/6 Series or an SW 8 Series bracket, respectively. The concrete foundation shown could be a wall or rectangular pier. An 8” concrete thickness is shown for the SW 4/6 Series and a 10” thickness is shown for the SW 8 Series brackets. The minimum distance to concrete edge in Figure 6.1 is 4 inches which is acceptable for all anchor types except 5/8” expansion anchors. The minimum distance to concrete edge in Figure 6.2 is 5 inches which is acceptable for all anchor types. Figure 6.3 applies to a bracket installed close to the edge of an opening in a foundation wall. It could also apply to a bracket installed on a rectangular concrete pier. This detail may be used for all anchor types except 5/8” expansion anchors. Figure 6.4 is an alternate detail for a bracket installed close to the edge of an opening or on a rectangular pier. This detail is acceptable for all anchor types except 1/2” and 5/8” expansion anchors.

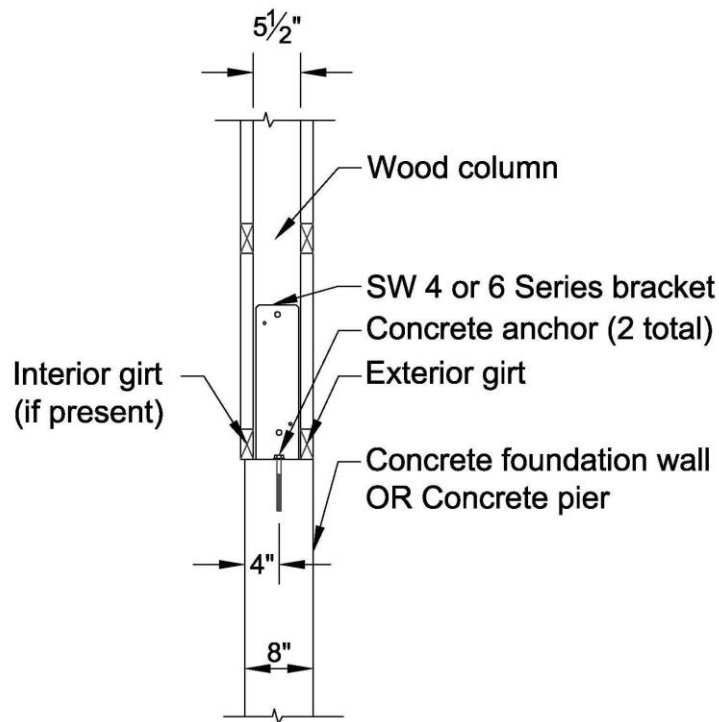

Note: Edge distance inadequate for  $\frac{5}{8}''\text{Ø}$  expansion anchors per Table 7.2

**Figure 6.1: Recommended Installation For SW 4 OR 6 Series Brackets**

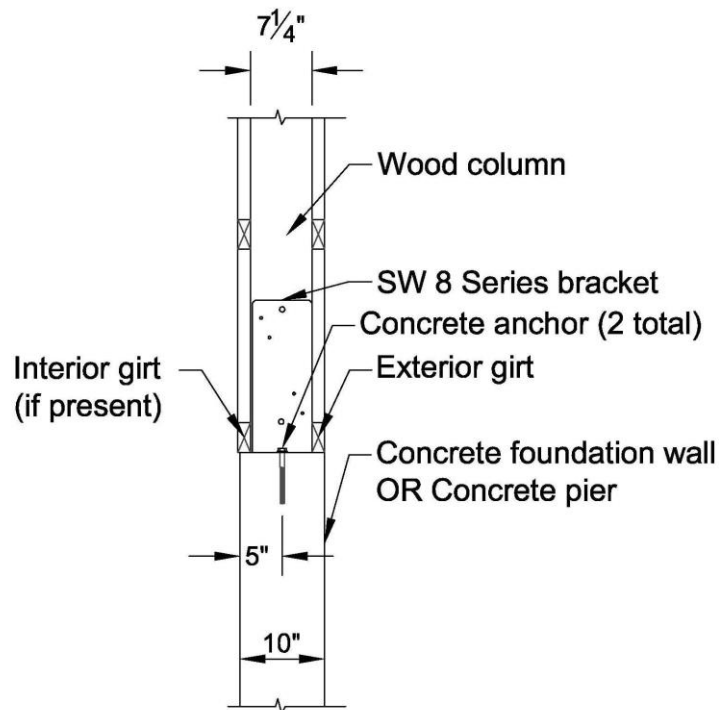

Note: Edge distance is adequate for all concrete anchors listed in Table 7.2

**Figure 6.2: Recommended Installation For SW 8 Series Brackets**

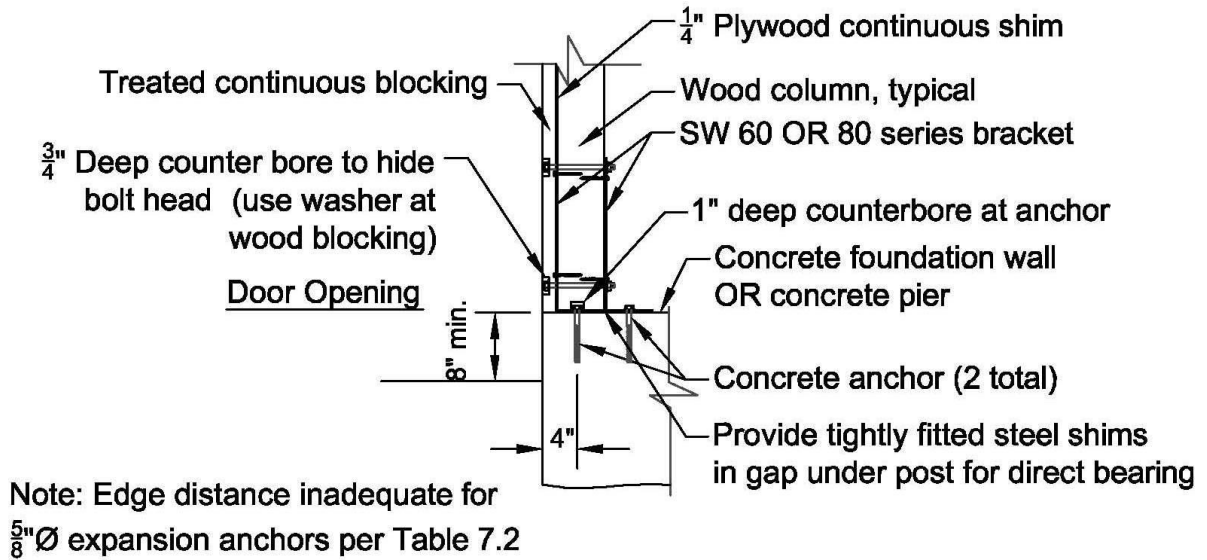

Figure 6.3: SW Door Edge Detail

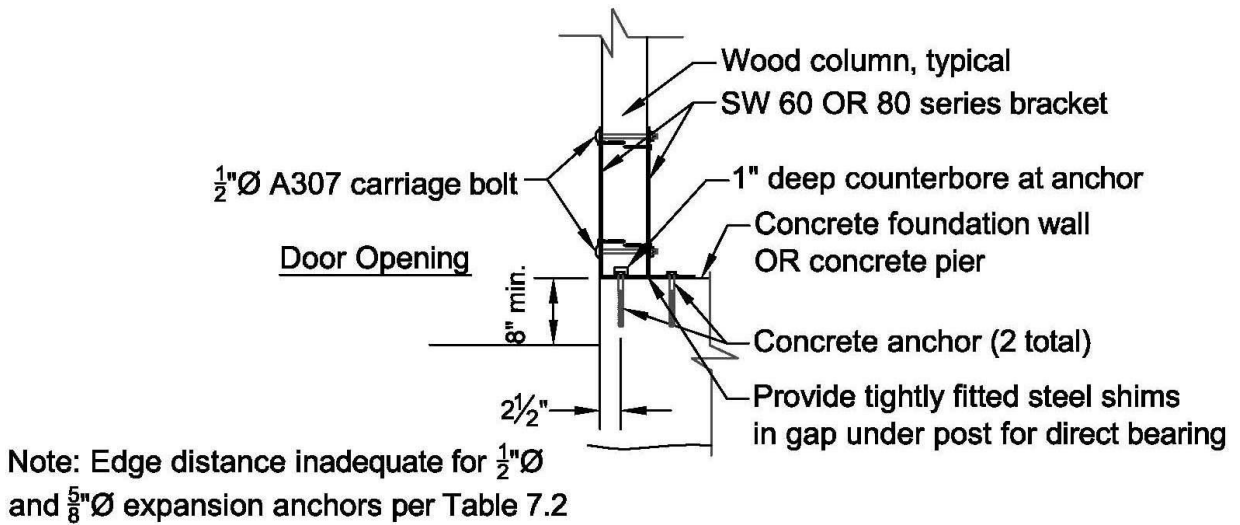

Figure 6.4: SW Door Edge Detail (Alternative)

## 7. Sturdi-Wall Bracket Design Chart

Table 7.1 shows the allowable shear and uplift for the wood to steel connection and the steel to concrete connection using the fasteners described above. Structural analysis of each Sturdi-Wall bracket model indicates that the allowable shear and uplift forces are controlled by the wood to steel or steel to concrete fasteners rather than the base metal. The steel to concrete design numbers assume a minimum concrete compressive strength ( $f'_c$ ) of 3000 psi. The tabulated allowable shear for the concrete anchors is the lesser of the shear capacity in concrete or shear capacity of the steel fastener, and allowable shear for the wood to steel connection is based upon the cumulative shear capacity of all bolts and screws in the connection.

The allowable loads for the wood to steel connection have been increased by 60% for wind or seismic loading and they must be reduced where other loads govern. Allowable loads for the concrete connection may be increased by 33.3% for wind or seismic loading where permitted by the locally applicable Building Code.

<b>Table 7.1: Allowable Shear and Uplift for Standard Sturdi-Wall Anchor Brackets</b>										
<i>All Loads in Pounds</i>	<b>Wood to Steel Connection</b>		<b>Steel to Concrete Connection</b>							
			<b>5/8" Anchor "L" Bolts</b>		<b>5/8" Epoxy Anchor</b>		<b>Expansion Anchor</b>		<b>5/8" Screw Anchor</b>	
<i>Model</i>	<i>Shear (160)</i>	<i>Uplift (160)</i>	<i>Shear (100)</i>	<i>Uplift (100)</i>	<i>Shear (100)</i>	<i>Uplift (100)</i>	<i>Shear (100)</i>	<i>Uplift (100)</i>	<i>Shear (100)</i>	<i>Uplift (100)</i>
<b>SW46</b>	5700	7520	6180	7050	6030	6950	2900 (a)	3670 (a)	3490	5900
<b>SW63</b>	5700	7520	6450	7050	6030	6950	2900 (a)	3670 (a)	3490	5900
<b>SW64</b>	5700	7520	6650	7050	6030	6950	2900 (a)	3670 (a)	3490	5900
<b>SW66</b>	5700	7520	6650	7050	6030	6950	2900 (a)	3670 (a)	3490	5900
<b>SW83</b>	8200	10020	8220	8225	7980	7720	4770 (b)	5250 (b)	4600	6570
<b>SW84</b>	8200	10020	8475	8225	7980	7720	4770 (b)	5250 (b)	4600	6570
<b>SW60 (pair)</b>	5700	7520	6180	7050	6030	6950	2900 (a)	3670 (a)	3490	5900
<b>SW6C (pair)</b>	3340	7741	6180	7050	6030	6950	2900 (a)	3670 (a)	3490	5900
<b>SW80 (pair)</b>	8200	10020	8220	8225	7980	7720	4770 (b)	5250 (b)	4600	6570
							(a) 1/2" Expansion Anchor			
							(b) 5/8" Expansion Anchor			

### Notes:

1. This chart is for Sturdi-Wall brackets used in a post-frame building application to connect wood columns to a concrete foundation.
2. The forces applied from posts to brackets are a vertical uplift force, and a horizontal shear force. Loads shown are not factored.
3. Wood to steel connections were calculated as per the NDS using Southern Yellow Pine columns, dry service conditions.
4. Allowable shear for the wood to steel connection is based upon the cumulative shear capacity of all fasteners in the connection.
5. The allowable loads in wood have been increased by 60% for wind or seismic loading, reduce where other loads govern.
6. The allowable concrete loads may be increased by 33.3 % for short term loading where permitted by Code.
7. Steel to concrete design numbers based on a minimum concrete compressive strength  $f'_c$  of 3000 psi
8. Anchor "L" bolts to be ASTM A307 grade C right angle bend typical
9. Epoxy anchors to be Hilti HIT-ICE adhesive anchor system using standard HAS Rods, or equal
10. Expansion anchors to be Hilti Kwik Bolt 3, or equal
11. Screw Anchors to be Powers "Wedge-Bolt" self-threading large diameter tapcon, or equal
12. Bolts are 1/2" diameter ASTM A307 (Grade 2) with hex nuts
13. Screws are to be 1/4" diameter x 3" Strong Drive Screws (SDS) by Simpson Strong Tie, or equal
14. Install all fasteners as per the manufacturer's recommendations and these notes
15. SW60, SW6C and SW80 shall be used as pairs and fastened using the recommended procedure for each bracket
16. Bending moment capacity of all Sturdi-Wall brackets assumed to be zero
17. Final bracket design should include a complete building analysis by a Design Professional.
18. Installation of anchors in concrete shall adhere to Table 7.2



The installation of anchors in concrete shall adhere to Table 7.2: Critical Anchor Dimensions in Concrete. This chart shows the minimum distance to the concrete edge, the minimum embedment depth into concrete, and the minimum center to center dimension for each of the anchor types. The minimum distance to the concrete edge is given as 4” for the SW6 series and 5” for the SW8 series. These dimensions assume that the concrete edge is aligned with 2x girts installed flat wise against the outside of the posts. The 5/8” expansion anchors cannot be used for the SW6 series brackets because the 4” edge distance is inadequate. The minimum center to center dimensions are based on the physical location of the holes in each bracket type. The minimum embedment depth into concrete should be measured from the bracket to concrete interface.

<b>Table 7.2: Critical Anchor Dimensions in Concrete</b>						
<b>Anchor Type</b>	<b>SW46, SW63, SW64, SW66, SW60</b>			<b>SW83, SW84, SW80</b>		
	<b>I (in)</b>	<b>II (in)</b>	<b>III (in)</b>	<b>I (in)</b>	<b>II (in)</b>	<b>III (in)</b>
<b>5/8" Anchor "L" Bolts</b>	2.5	8	8.375	2.5	8	9.375
<b>5/8" Epoxy Anchor</b>	2.5	5	8.375	2.5	5	9.375
<b>1/2" Expansion Anchors</b>	3.75	3.5	8.375	3.75	3.5	9.375
<b>5/8" Expansion Anchors</b>	-	-	-	4.5	4	9.375
<b>5/8" Screw Anchor</b>	2	4.5	8.375	2	4.5	9.375
<b>Notes:</b>	I = Min. distance to concrete edge II = Min. embedment depth into concrete III = Min. Center to Center Dimension					

## Part 2: Sturdi-Wall Plus (Wet Set) Models

### 8. Sturdi-Wall Plus Design Overview

The Sturdi-Wall Plus anchor brackets are designed to connect wood columns to a concrete foundation in a typical post frame building application using a wet set installation method. This manual contains drawings and descriptions for each of the Sturdi-Wall Plus models, a chart showing allowable shear, uplift, and bending moment for Sturdi-Wall Plus base brackets, description of method for attachment to concrete, and discussion of design assumptions. Drill set installation is covered in Part 1 of this manual.

### 9. Sturdi-Wall Plus Descriptions

Dimensions for the SWP46, SWP66, SWP63, SWP64, SWP83, SWP84, and SWP85 are given in Figure 9.1. The brackets are constructed with  $\frac{1}{4}$ " structural steel plate with a minimum yield strength of 40 ksi, and  $\frac{1}{4}$ " fillet welds of E70XX electrodes. Each assembled bracket has a proprietary powder coat finish. The SWP46 is to be used with a 4x6 wood post, SWP66 with a 6x6 wood post, SWP63 with a 3-ply 2x6 mechanically laminated column, SWP64 with a 4-ply 2x6 laminated column, SWP83 with a 3-ply 2x8 laminated column, SWP84 with a 4-ply 2x8 laminated column, and SWP85 with a 5-ply 2x8 laminated column or 8x8 wood post. The inside dimension of the brackets allow for an  $\frac{1}{8}$ " total tolerance between the steel bracket and wood column. Glued laminated columns are acceptable; however, appropriately sized wood shims need to be added on both sides of the pocket to provide a snug fit as shown in Figure 9.2 ( $\frac{1}{8}$ " total tolerance is acceptable). **The shim should be APA B-C Exterior plywood (or equivalent), no more than  $\frac{1}{4}$ " thick, and have the same dimensions as the vertical leg of the bracket. The shim should be fastened to the column with 2 beads of Builders Choice 490 construction adhesive by Liquid Nails (or equal) and (6) 0.113"x2.375" nails.**

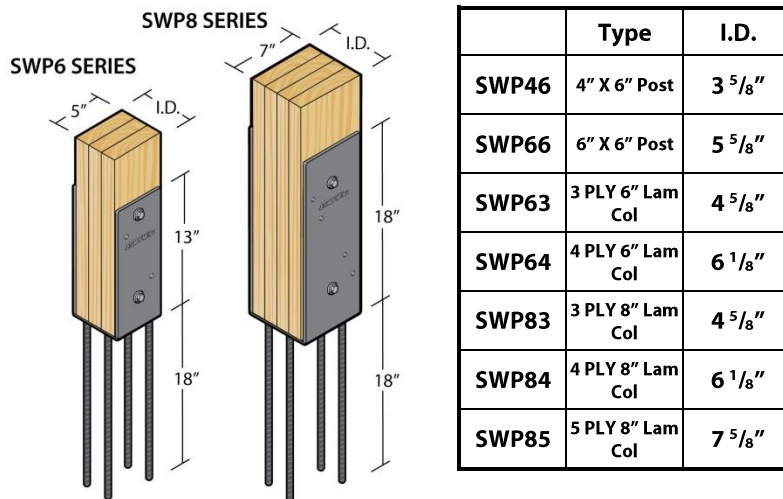
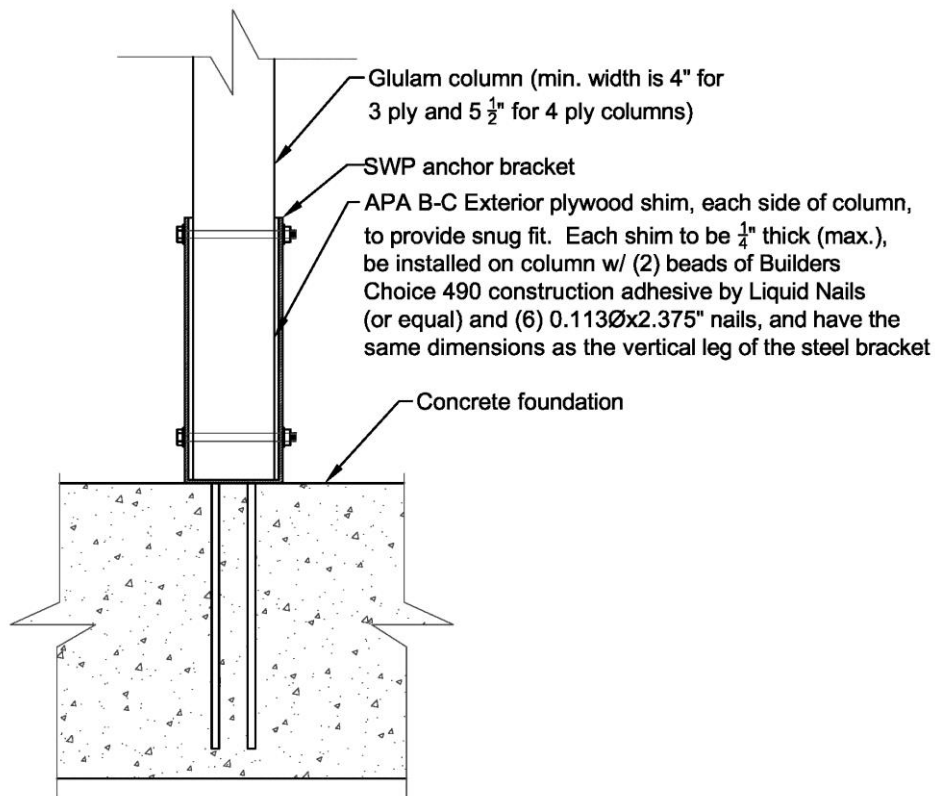

Figure 9.1: Sturdi-Wall Plus Descriptions



**Figure 9.2: Sturdi-Wall Plus Shim Detail**

## 10. Steel Bracket Design

The forces applied from the building columns to Sturdi-Wall Plus brackets are a vertical uplift force, a downward gravity force, a horizontal shear force, and a moment about the strong axis of the column. The wood columns need direct bearing on the bottom to transfer axial loads directly into the concrete wall or foundation. Unlike the Standard Sturdi-Wall brackets, the Sturdi-Wall Plus brackets do have moment capacity and an allowable bending moment has been developed for each model. The building must be designed to resist lateral loads through diaphragm action or other bracing means which are assumed to be adequate to take up weak axis bending. All mechanical fasteners are to be installed as per the manufacturer's recommendations and this design manual. The brackets consist of 1/4" steel with A706 weldable reinforcing bars welded to the base of the bracket, #4 (1/2") for the SWP 4 and 6 Series brackets and #5 (5/8") for the SWP 8 Series brackets and 5/8" diameter holes for the 1/2" diameter bolts in the vertical legs. The brackets also have holes for screws near the bolts in the vertical legs.

## 11. Concrete Reinforcing Bar Design

This manual includes recommendations for the use of concrete reinforcing bar (rebar) to provide a moment connection between the steel to concrete interface.

### 11.1 #4 (1/2" diameter) Rebar

The #4 rebar anchors are to be weldable ASTM A706 grade 60 straight rebar, 18" long. Four of the #4 rebar are welded to the bottom of the SWP 4 and 6 Series base with a minimum of 1/4" continuous fillet weld. One layer of the double 1/4" steel base has a hole in it to accept the rebar

and provide superior weld penetration. The rebar is then cast in place by being set in wet concrete shortly after a wall or foundation pour. The rebar must be placed within the recommended cover noted in the design chart. The cast in place rebar allows for bending moments to transfer from the column to the steel bracket and into the concrete wall or foundation.

#### 11.2 #5 ( $\frac{5}{8}$ " diameter) Rebar

The #5 rebar anchors are to be weldable ASTM A706 grade 60 straight rebar, 18" long. Four of the #5 rebar are welded to the bottom of the SWP 8 Series base with a minimum of  $\frac{1}{4}$ " continuous fillet weld. One layer of the double  $\frac{1}{4}$ " steel base has a hole thru it to accept the rebar and provide superior weld penetration. The rebar is then cast in place by being set in wet concrete shortly after a wall or foundation pour. The rebar must be placed within the recommended cover noted in the design chart. The cast in place rebar allows for bending moments to transfer from the column to the steel bracket and into the concrete wall or foundation.

### 12. Wood Connection

The wood to steel connection is made with (2)  $\frac{1}{2}$ " diameter A325 (grade 5) bolts in double shear and  $\frac{1}{4}$ " x 3" strong drive screws (SDS) by Simpson Strong Tie (or equal) in single shear installed from each side. Typically, one screw is installed from each side of the bracket at each bolt except the SWP8 series has 2 screws on each side at each bolt. Screws help prevent stress concentrations around the bolt which would cause splitting of the wood members. The wood to steel connection was analyzed as per the National Design Specification for Wood Construction by the American Forest and Paper Association using Southern Yellow Pine wood columns.

No wet service reductions have been made since the wood portion is not in contact with the soil or concrete and it is assumed to be used in an enclosed building. If the SWP brackets are to be used in an environment where the moisture content of the wood in service will exceed 19% for an extended period of time, pressure treated wood and galvanized or stainless steel bolts should be used, and a wet service factor of 0.7 applied to the allowable shear, uplift, and bending moment values in Table 14.1. The design of the wood post above and the concrete foundation below the Sturdi-Wall Plus bracket are the responsibility of others. Lateral bracing of the building is also the responsibility of others.

A barrier membrane between the pressure treated wood and the steel bracket is not necessary. The steel bracket is protected by the Perma-Column EpoxyZirc Coating pretreatment, a process in which Zirconium molecules chemically crystallize the steel molecules, effectively changing the surface of the steel into a compound that does not oxidize. The ASTM B-117 Salt Spray Testing results show that the Perma-Column EpoxyZirc Coating outperforms the G185 galvanized coating, which is thicker than the galvanized coating prescribed by the ASTM A653.

### 13. Recommended Sturdi-Wall Plus Installation Details

ACI 318-08, Section 7.7 contains concrete cover requirements for protection of reinforcement against moisture from weather and earth. For cast-in-place concrete, the minimum clear cover is 3" when cast against and permanently exposed to earth, and 2" when exposed to earth and weather. Since foundation walls and piers into which the Sturdi-Wall Plus brackets get installed are normally formed,

not cast against earth, they fall into the second category. Lesser concrete cover requirements may apply if the concrete foundation is not exposed to earth or weather.

Figures 13.1 and 13.2 illustrate the recommended installation of an SWP 4/6 Series and an SWP 8 Series bracket, respectively. The concrete foundation shown could be a wall or rectangular pier. An 8" concrete thickness is shown for the SWP 4/6 Series and a 10" thickness is shown for the SWP 8 Series brackets. The clear cover to the reinforcing bars of the SWP brackets for both cases is greater than 2" so they are adequate for earth and weather exposure. Figure 13.3 applies to a bracket installed close to the edge of an opening in a foundation wall. It could also apply to a bracket installed on a rectangular concrete pier. Figure 13.4 applies to a bracket installed on a round concrete pier such as a sonotube. The top of the pier is squared off to allow for attachment of a skirt board around the building perimeter. The skirt board provides protection for the concrete such that it is not exposed to weather or in contact with the ground. The clear concrete cover requirement for this situation is 1-1/2" per ACI. If the brackets are used in a situation where the foundation is cast against and permanently exposed to earth, 3" clear cover is required.

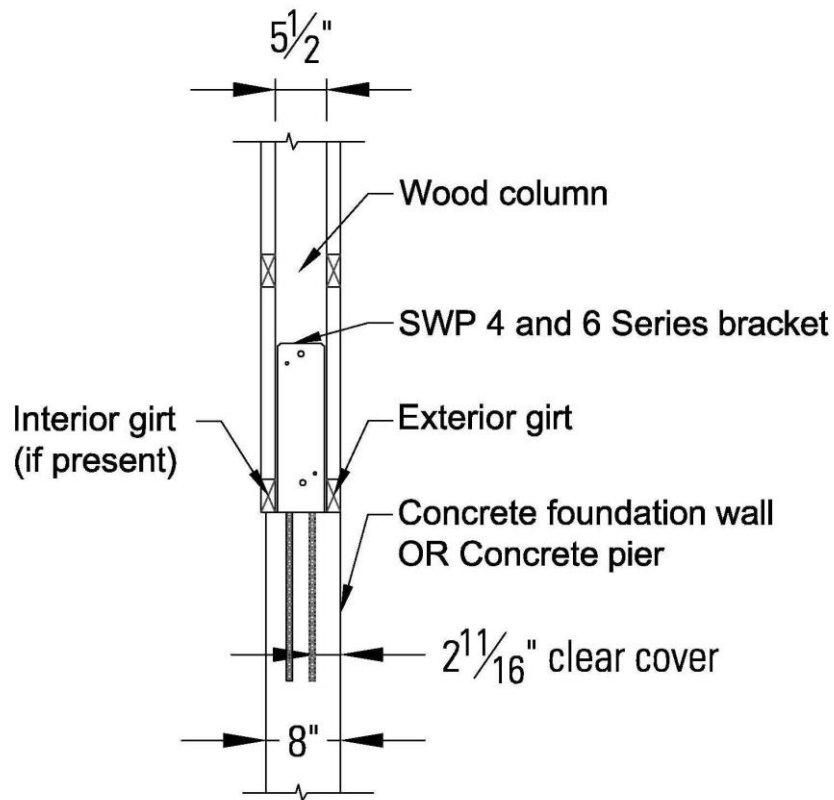

**Figure 13.1: Recommended Installation  
For SWP 4 and 6 Series Brackets**

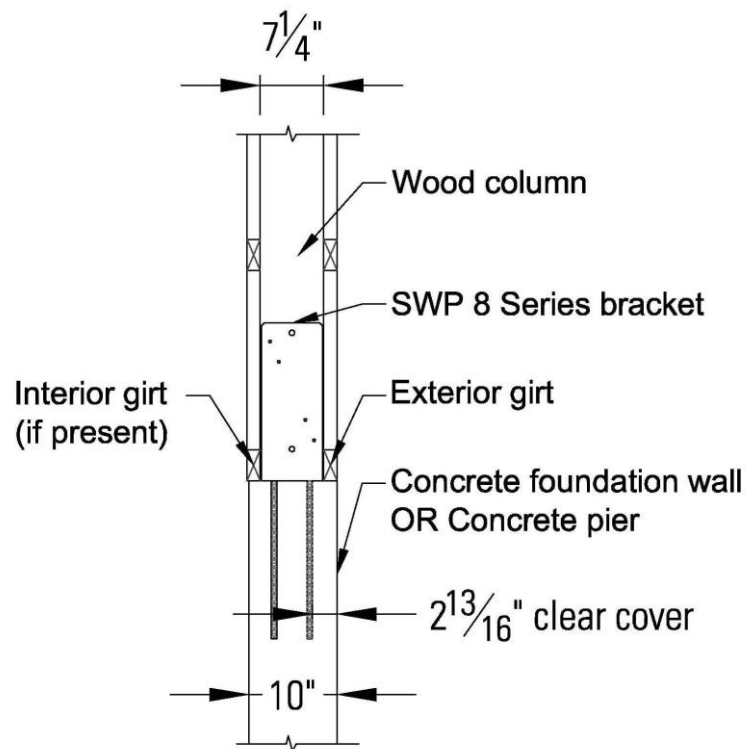

**Figure 13.2: Recommended Installation  
For SWP 8 Series Brackets**

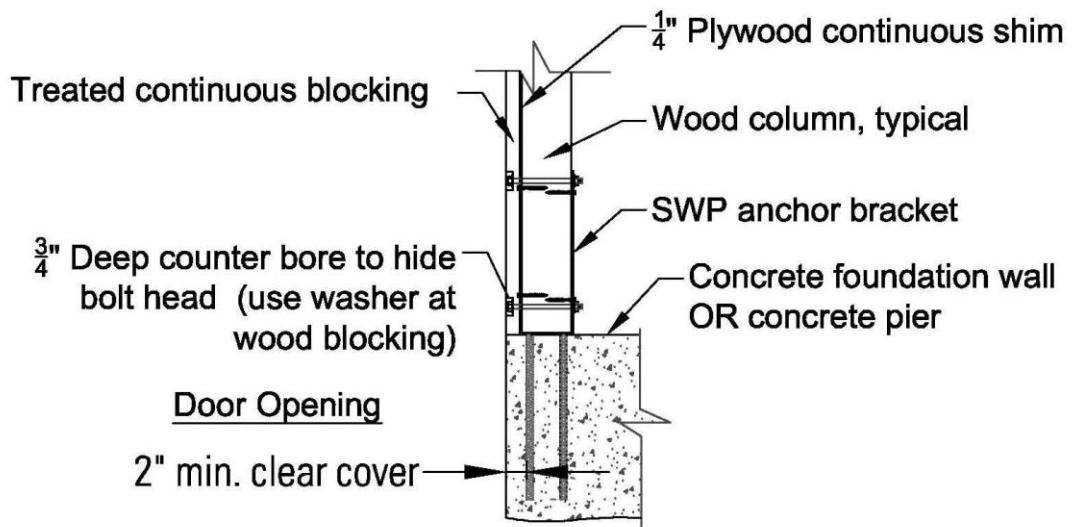

**Figure 13.3: SWP Door Edge Detail**

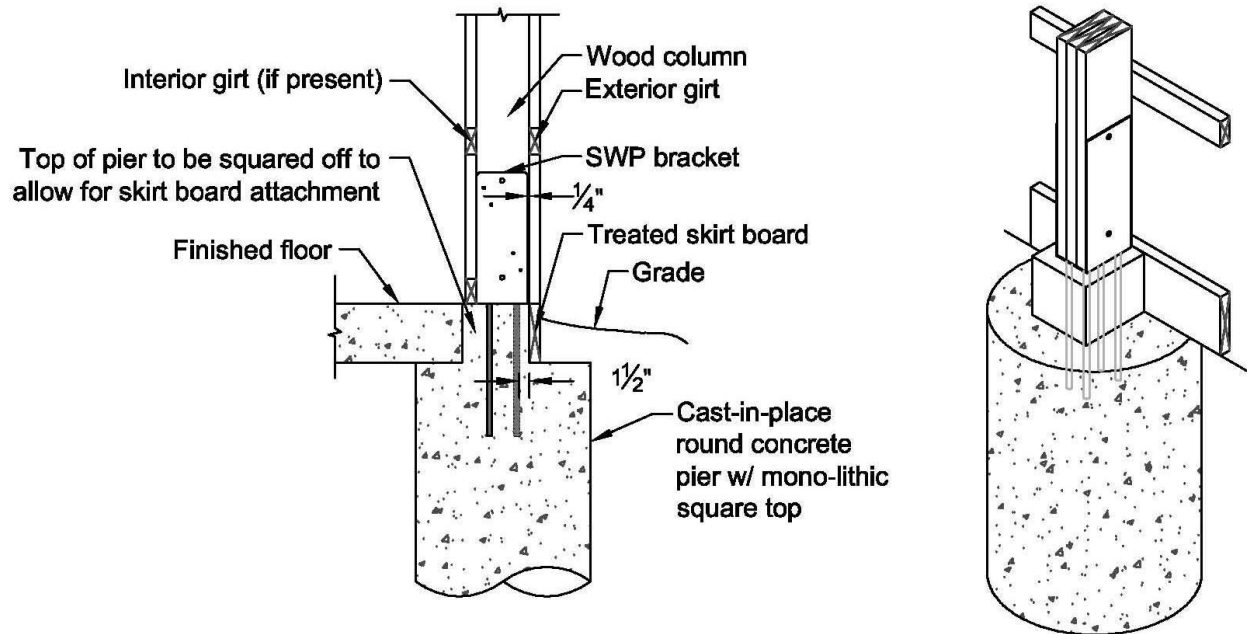

**Figure 13.4: SWP Connection to Round Concrete Pier**

#### 14. Sturdi-Wall Plus Bracket Design Chart

Table 14.1 shows the allowable shear, uplift, and bending moment for the wood to steel connection and the steel to concrete connection using the fasteners described above. The allowable loads for the wood to steel connection have been increased by 60% for wind or seismic loading, reduce where other loads govern. The allowable loads for the concrete connection have been divided by 1.6 to convert from Load and Resistance Factor Design (LRFD) to Allowable Stress Design (ASD). The steel to concrete design numbers are based on a minimum concrete compressive strength ( $f'_c$ ) of 4000 psi.

The rebar design capacities are governed by the development length of the rebar calculated according to the American Concrete Institute Building Code ACI 318-08. The length of rebar required for the rebar to reach its full load capacity is 19" for #4 rebar and 23.7" for #5 rebar. A reduction factor is applied to the calculated development lengths to obtain the charted required rebar lengths. The reduction factor is a ratio of the actual tension developed in the rebar based on the capacity of the wood to steel connection to the fully developed tension capacity of the rebar. In all cases, except for the SWP64, the wood to steel connection governs the design. For the SWP64, the rebar capacity governs the design. When the Sturdi-Wall Plus brackets are placed in wet concrete, care shall be taken to ensure that the concrete is not so wet that the brackets sink below the base plate and not so dry that the concrete will not flow around and adhere to the rebar. Ideally, the consistency of the concrete should be such that the rebar can be easily inserted in the concrete and the base of the steel bracket can float on the surface of the concrete. The entire length of rebar shall be embedded in the concrete such that the bottom of the steel base plate bears on the surface of the concrete.

Although design of the concrete wall or foundation into which the Sturdi-Wall Plus brackets are cast is the responsibility of others, it is important that the concrete wall or foundation is designed to resist the shear, uplift, and bending moment forces that are transferred from the column to the concrete wall or foundation. The concrete foundation must also be capable of supporting the gravity loads from the

columns and transferring the loads without exceeding the allowable bearing pressure of the soil at the specific site location. Provide adequate weight in the concrete foundation to resist uplift.

<b>Table 14.1: Allowable Shear, Uplift, and Bending Moment for Sturdi-Wall Plus Anchor Brackets</b>							
<b>Sturdi-Wall Plus Bracket Components</b>				<b>Sturdi-Wall Plus Bracket Capacities</b>			<b>Required Development Length for Rebar</b>
<b>Model</b>	<b>Post Size</b>	<b>Perma-Column Bracket Spec.</b>	<b>Rebar Size</b>	<b>Shear (lbs)</b>	<b>Uplift (lbs)</b>	<b>Moment (in-lbs)</b>	
SWP46	4x6	PC4600	(# 4) 1/2"	6560	9020	28000	18"
SWP66	6x6	PC6600	(# 4) 1/2"	6640	9020	28000	18"
SWP63	3 ply 2x6	PC6300	(# 4) 1/2"	6640	9020	28000	18"
SWP64	4 ply 2x6	PC6400	(# 4) 1/2"	6640	9020	30000	18"
SWP83	3 ply 2x8	PC8300	(# 5) 5/8"	9140	11520	59000	18"
SWP84	4 ply 2x8	PC8400	(# 5) 5/8"	9140	11520	59000	18"
SWP85	5 ply 2x8	PC8500	(#5) 5/8"	9140	11520	59000	18"

**Notes:**

1. This chart is for Sturdi-Wall Plus brackets for use in post-frame building applications to connect wood columns to a concrete wall or foundation.
2. Loads applied to the brackets from the columns are a vertical uplift force, horizontal shear force, and a moment about the strong axis of the column.
3. Column weak axis loads are assumed to be taken by adequate diaphragm action of roof and shearwalls
4. Wood to steel connections were calculated as per the NDS using Southern Yellow Pine columns, dry service conditions
5. The bolted connection of the Perma-Column Bracket to the post governed all allowable bending moments except for the SWP64 in which the rebar development length governed.
6. The allowable loads in wood have been increased by 60% for wind or seismic loading.
7. The allowable loads in concrete have been divided by 1.6 to convert from LRFD to ASD.
8. Concrete design numbers are based on a minimum concrete compressive strength of 4000 psi
9. All rebar is weldable A706, Grade 60, #4 for 4 and 6 series brackets and #5 for 8 series brackets
10. Bolts are 1/2" diameter ASTM A325 (Grade 5) with hex nuts
11. Screws are to be 1/4" diameter x 3" Strong Drive Screws (SDS) by Simpson Strong Tie, or equal
12. The calculated full development length of deformed bars in tension according to the ACI 318-08 is 19" for #4 rebar and 23.7" for #5 rebar, development length reflects straight rebar, no standard hooks are used.
13. The required development length was obtained by multiplying the calculated full development length by the ratio of the actual tension in the rebar due to the allowable bending moment to the fully developed rebar tension.
14. Minimum development length for any rebar shall not be less than 12" as per ACI 318-08, Section 12.2.1
15. Minimum concrete cover for rebar shall be 3" when cast against and permanently exposed to earth, or 2" when exposed to earth or weather as per ACI 318-08, Section 7.7 (lesser cover requirements may apply)
16. Wood column above the bracket and concrete foundation below the bracket to be designed by others
17. Gravity loads shall be supported on an adequate foundation
18. Uplift loads shall be resisted by the weight of the concrete foundation
19. Install all fasteners as per the manufacturers recommendations and these notes
20. Final bracket design should include a complete building analysis performed by a design professional



## 15. Summary and Conclusion

Sturdi-Wall anchor brackets are designed to be used in a post-frame building application to connect wood columns to a concrete foundation. This can be done in a wet set or drill set application depending on model of bracket used. Standard Sturdi-Wall anchor brackets do not transfer bending moment from the column into the foundation. Therefore, it is critical the supported structure be designed to resist lateral loads through diaphragm action or other bracing means. Sturdi-Wall Plus anchor brackets can only be installed in a wet set application in order for the rebar-to-concrete bond to develop correctly and create a connection that allows for bending moment transfer from the column to the steel bracket and into the foundation. Since the bracket capacities are based on strong axis bending of the column, it is important that the supported structure be designed to resist lateral loads through diaphragm action of roof and shear walls or other bracing means. It is also important that the concrete wall or foundation is designed to resist the uplift, shear, and bending moment forces transferred from the Sturdi-Wall Plus bracket.



*This design manual can be downloaded from [www.permacolumn.com](http://www.permacolumn.com)*